

# STINGER EQUIPMENT



## EZ-AER OPERATOR'S MANUAL

## Introduction

---

Thank you for purchasing this Stinger Equipment, Inc. product. This manual will explain the safety, maintenance, and operation of your unit.

## Safety

---

All operators should:

- Read the operator's manual in its entirety before operating.
- Be adequately trained on the controls and their functions.
- Be over the age of 18
- Be free of any impairments
- In good physical health
- Stop usage before overexertion
- Wear Personal Protective Equipment including, but not limited to hearing protection, steel toe boots, safety glasses, gloves and, high visibility clothing
- Ensure all safety equipment, shields, and covers are in place and free of defects. Do not use this equipment if any guards or safety decals are not in place.
- Perform an inspection of the unit before each use. Ensure all fasteners are secure, the tires are properly inflated, and the engine oil level is correct.
- Never place hands or feet near the tines or other moving components

## Safety (continued)

---

All operators should:

- Operate outdoors in well-ventilated areas
- Do not operate on slopes great than 15 degrees or in hazardous conditions
- Realize conditions could cause even moderate slopes to be too steep. Discontinue immediately if the machine can't cross straight across an incline.
- Do not use if terrain exceeds skill or comfort level.
- Clear the worksite of foreign objects, pets, and people
- Always consider what might be below the turf before aerating. Does the property have unground utilities, an invisible dog fence, low voltage lighting, irrigation., etc.
- Calling 811 and/or a private locate company to mark utilities

### Refueling the unit:

- Use an OSHA approved fuel can
- Do not fuel while the unit is running or hot
- No smoking while refueling
- Do not refuel around any source of ignition including sparks and flames
- Refuel only outside and on level ground
- Do not overfill the unit
- Secure the fuel cap

## Safety (continued)

---



This Symbol means **ATTENTION! TAKE NOTICE!**

Your attention is needed to ensure your safety and the safety of those around you. This Symbol is followed by a Signal word describing the level of hazard. You will see these safety labels throughout this manual and on all equipment.

### Signal word definitions:



**DANGER** indicates an imminently hazardous situation that **WILL** result in death or serious injury if not avoided.



**WARNING** indicates a potentially hazardous situation that **COULD** result in death or serious injury if not avoided.



**CAUTION** indicates a potentially hazardous situation that may result in minor or moderate injury if not avoided. It may also be used to alert against unsafe practices or property damage.

## Safety (continued)

---



- Read the owners manual before use.
- Do not Operate indoors.
- Do not refuel while engine is hot.
- Wear eye and ear protection at all times.
- Keep all clothing and body parts away from drive components.
- Discontinue use if any shields, guards or safety equipment is not in place.
- Use caution on hills.
- Keep hands and feet clear at all times!
- Keep away from all moving parts.



60-3006



# Operation

---

## Preparing to Aerate

1. Clear the worksite of people, pets, and foreign objects
2. Mark underground sprinklers and utilities
3. Ensure ground is moist. Watering the day before aeration can produce the best results.
4. Ensure all shields, guards and decals are in place.

## Starting and Stopping the Engine

1. When the engine is cold pull the throttle/choke all the way back to set choke, as shown in figure 1.
2. Give a quick pull to the recoil to start the engine.
3. Allow the unit to warm up and slide the throttle forward to the desired rpm.
4. To turn the engine off, move the throttle/choke lever fully forward.

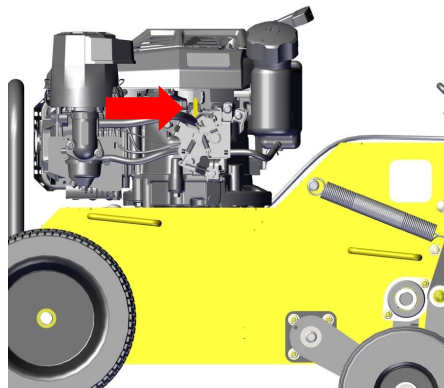

Figure 1

## Usage

1. Lower aeration tines into the ground by lowering the tine handle, as shown in figure 2.

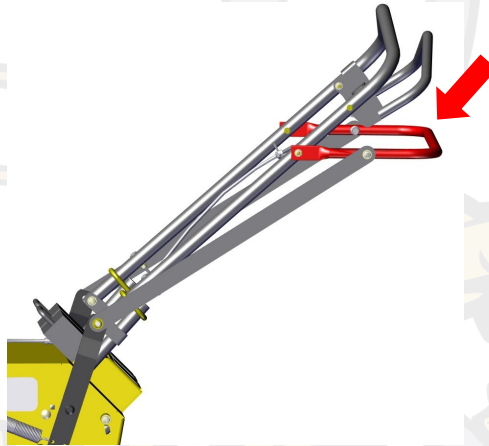

Figure 2

2. Squeeze the motion control bar as shown in Figure 10 to move the unit forward. The more pressure applied, the greater the speed.

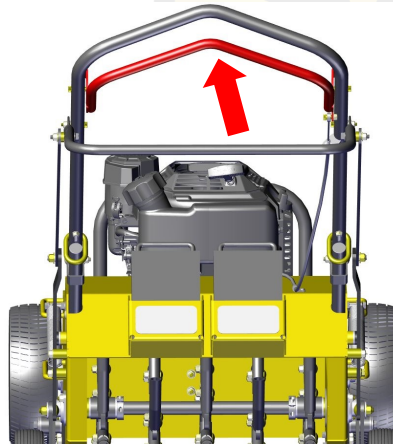

Figure 3

## Usage (continued)

3. Release the motion control bar to stop the unit's movement.
4. Push the handle bars in the opposite direction you want to turn. The greater the push the faster the unit will turn.  
Note: Outline the property and continue in descending circles. Most turns can be made with the tines in the ground.
5. For 180 degree turns lift the tines out of the ground by raising the tine handle. Rotate the unit into position and lower the tines
6. Always lift tines before crossing over concrete, tree roots, and other hard surfaces.

## First Time Use

1. Operate the unit at low speed and in a wide-open area.
2. Practice making wide turns first and tighter turns as you get used to using the machine and the controls.
3. You do not have to raise the tines to make most turns.  
Raise the tines to transport the unit across hard surfaces, as severe damage may occur.

## Transport

---

### Folding Handles

- Slide lock rings up and over the bolt as shown in figure 4  
Note: If the lock ring is tight, wiggle the handlebars
- Fold the handle bars forward

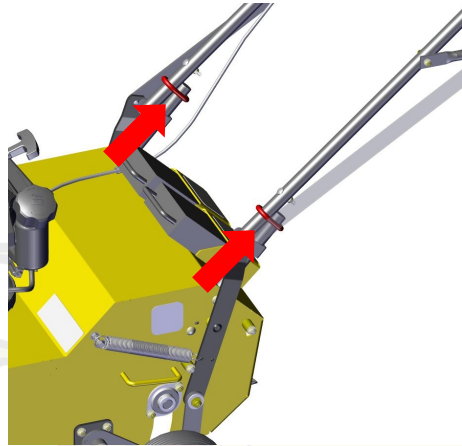

Figure 4

## Loading

**⚠ WARNING** Unit exceeds 100lbs always use TEAM LIFT.

- Turn engine off
- Shut fuel off
- Remove weights
- Utilize the four lifting handles as shown in figure 5.



Figure 5

## Maintenance

---

Turn the unit off and remove the spark plug as shown in Figure 6 before performing any maintenance.

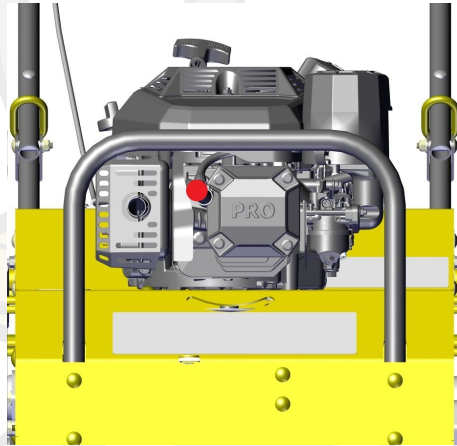

Figure 6

### Hydrostatic transmission

- The hydrostatic transmission features a maintenance-free design.

### Belt

- Inspect the engine belt every 100 hours, or annually, for signs of wear.

#### Belt Replacement Procedure:

1. Loosen idler pulley as shown in figure 7.
2. Take note of the belt orientation and pathway in figure 8 before removing and discarding the old belt.
3. Replace with a new belt and push the pulley away from the engine to increase tension. There should be 1/4" to 3/8" deflection in the center of the belt when tensioned properly.

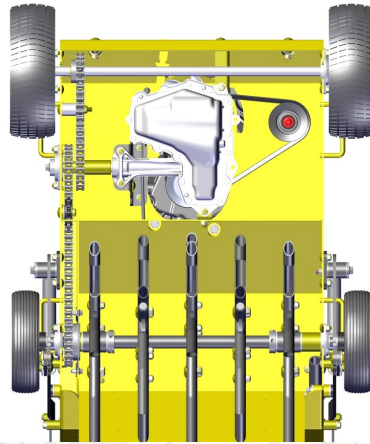

Figure 7

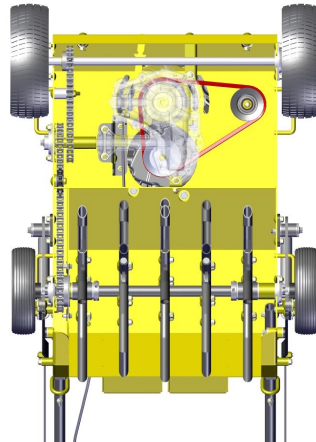

Figure 8

## Chain

- Inspect the chain after the first 4 hours, then daily the first week, and weekly afterward, and adjust as needed. A properly tensioned chain should have 1/4-3/8" of slack.
- Make sure the chain is clean and free of any debris.

#### Chain Tensioning:

1. Loosen idler sprockets nut as shown in Figure 9 but do not remove.

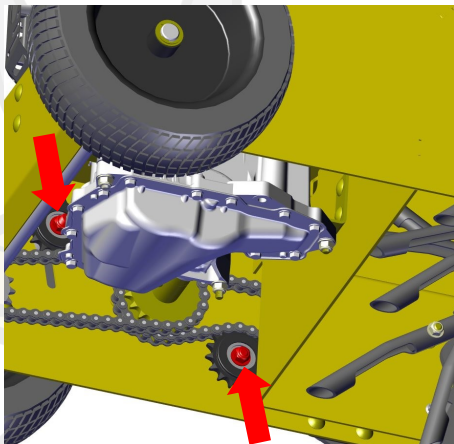

Figure 9

2. Slide the sprocket towards the centerline of the chain to increase chain tension and retighten the idler sprocket nuts.
3. Lubricate both chains with cycle chain lube weekly

#### Tine Core Depth Adjustment

1. Loosen depth spacer as shown in figure 10 on both sides of the unit.
2. Slide spacer up for the deepest core, and down for the shallowest core.
3. Ensure both sides match and retighten the bolt

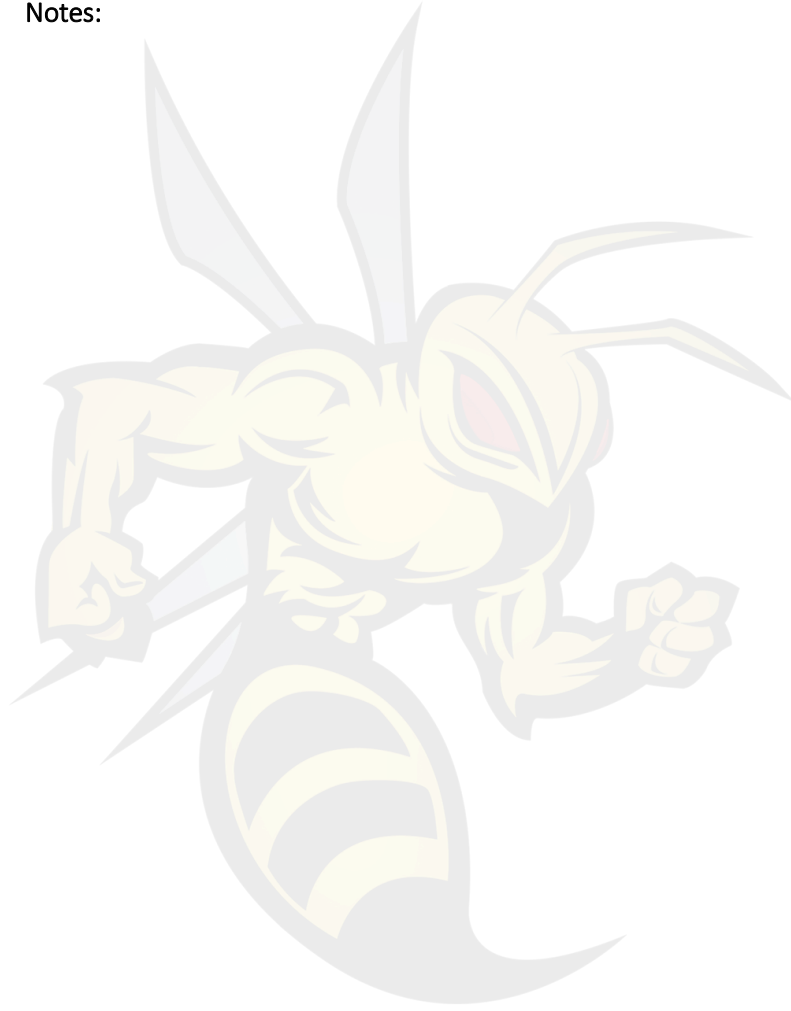

Figure 10

## Engine

- Run unleaded gasoline with an octane rating of 86 or higher and 10% or less ethanol.
- Check engine oil with engine level (not tilted) daily
- Drain the engine oil by removing the oil plug in figure 5.
- Change the oil within the first month or 10 hours, do not overfill the unit.
- Depending on conditions, regular oil changes are required every six months, 50 hours, or sooner.
- Follow engine manufacturer's guideline for oil type.
- Clean/replace the air filter every three months or 25 hours.
- See supplemental Engine manufacturer booklet for additional maintenance procedures and requirements

Notes:



Notes:

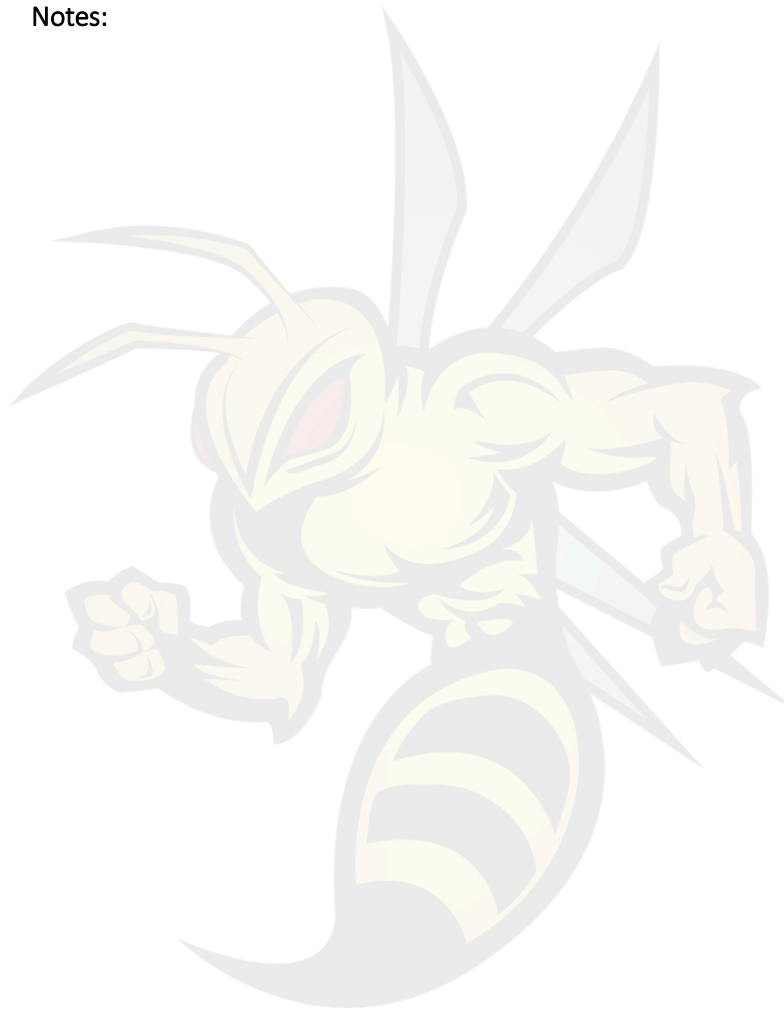

# Get the App



## Parts Orders Have Never Been This Easy!



www.

.com

4701 W Highway 146 Buckner, KY 40010

(502) 536-0716